

## Data Sheet for Piston Seal K09

### Technical Data

Seal Materials	Max. Operating Temp °C	Pressure MPa	Glide Speed m/s
APU + AR1+ ATL	100	50	0.5
AF2 + AR1+ ATL	100	50	0.5

Media: Mineral oil-based hydraulic fluids.

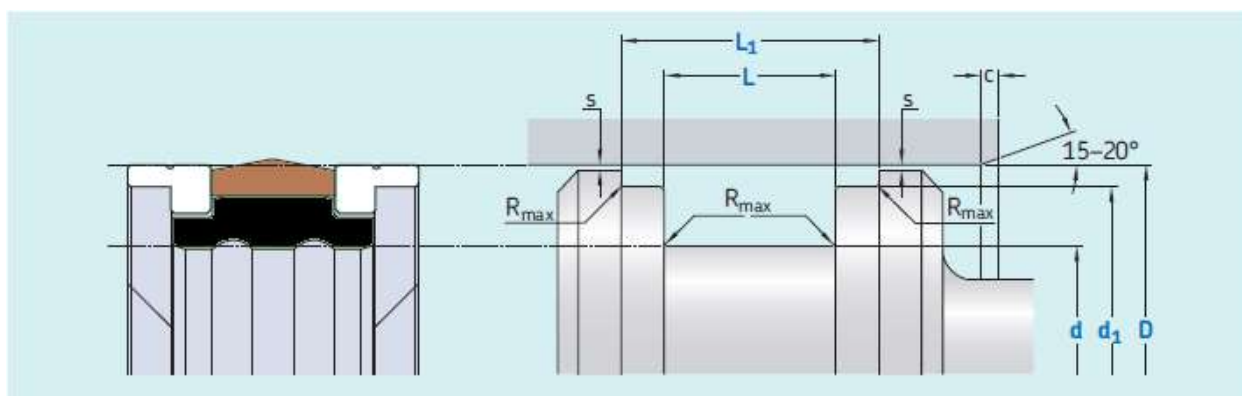

$R_{max}$ : 0.3 mm

Standard dimensions					Max. radial extrusion clearance S (400 Bars)
Bore Dia range D mm	Groove OD d mm	Groove Step Dia d <sub>1</sub> mm	Groove Length L mm	Total Length L <sub>1</sub> mm	
20-50	D-10	D-3	12.5	20.5	0.35
50-80	D-15	D-4	20	28	0.50
80-150	D-20	D-5	25	36	0.65
150-400	D-25	D-6	32	46	0.80
400-600	D-30	D-8	36	50	1.00

Note: For temp above 70°C extrusion clearance have to be lower

**Ordering example: Piston Seal K09 80 x 95/100 x 25/36/ AR1+ATL + AF2**