

## Data Sheet for Piston Seal K10-12

### Technical Data

Seal Materials	Max. Operating Temp °C	Pressure MPa	Glide Speed m/s
APU + ATL	100	50	0.5
AR2+ AF2	200	25	0.5

Media: Mineral oil-based hydraulic fluids.

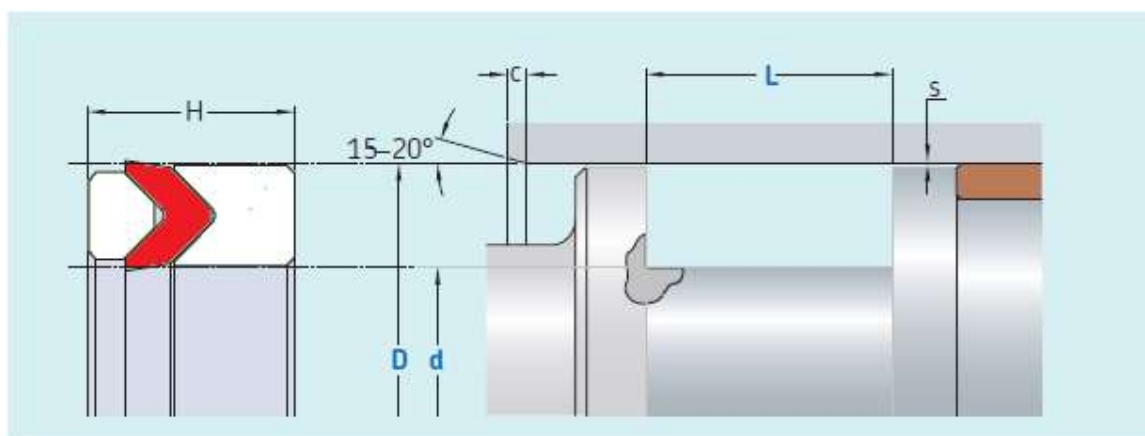

$R_{max}$ : 0.4mm

Standard dimensions			Max. radial extrusion clearance S
Bore Dia range D mm	Groove OD d mm	Groove Length L mm	Pressure 500 bars
10-40	D-10	10	0.25
40-75	D-15	12.5	0.38
75-150	D-20	21	0.50
150-200	D-25	26	0.63
200-300	D-30	34	0.75
>300	D-40	42	1.00

Note: For temp above 70°C extrusion clearance have to be lower

**Ordering example: Piston Seal K10-12 100 x 120 x 21 (1+1+1) / APU +ATL**