

Data Sheet for Piston Seal K19

Technical Data

Seal Materials	Operating Temp range °C	Pressure MPa	Glide Speed m/s
AF2 + SS 316L	-200 to 260	20	10

Media: Practically all fluids, chemicals and gases.

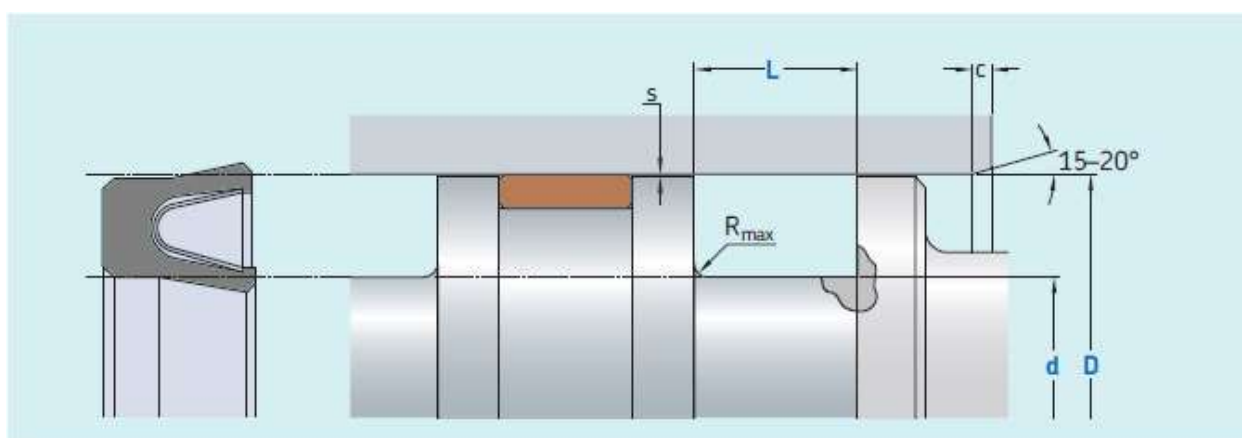

R_{max}: 0.4 to 0.6 mm

Standard dimensions			Max. radial extrusion clearance S		
Bore Dia range D mm	Groove OD d mm	Groove Length L mm	Pressure (Bars)		
			100	200	300
10-20	D-4.5	3.6	0.12	0.1	0.08
20-50	D-6.2	4.8	0.17	0.12	0.1
50-120	D-9.4	7.1	0.22	0.17	0.12
120-200	D-12.2	9.5	0.31	0.25	0.15

Note: For temp above 80°C extrusion clearance have to be lower

Ordering example: Piston Seal K19 23.8 x 30 x 4.8 / AF2